



Saeco



PicoBaristo

DELUXE



WWW.SAECO.COM/CARE

SM5573, SM5572, SM5570

EN USER MANUAL
DA BRUGERVEJLEDNING
DE BENUTZERHANDBUCH
ES MANUAL DEL USUARIO
FR MODE D'EMPLOI
IT MANUALE UTENTE

NL GEBRUIKSAANWIJZING
NO BRUKERHÅNDBOK
PT MANUAL DO UTILIZADOR
FI KÄYTTÖOPAS
SV ANVÄNDARHANDBOK
EL ΕΓΧΕΙΡΙΔΙΟ ΧΡΗΣΗΣ

PHILIPS

Saeco, a Philips brand



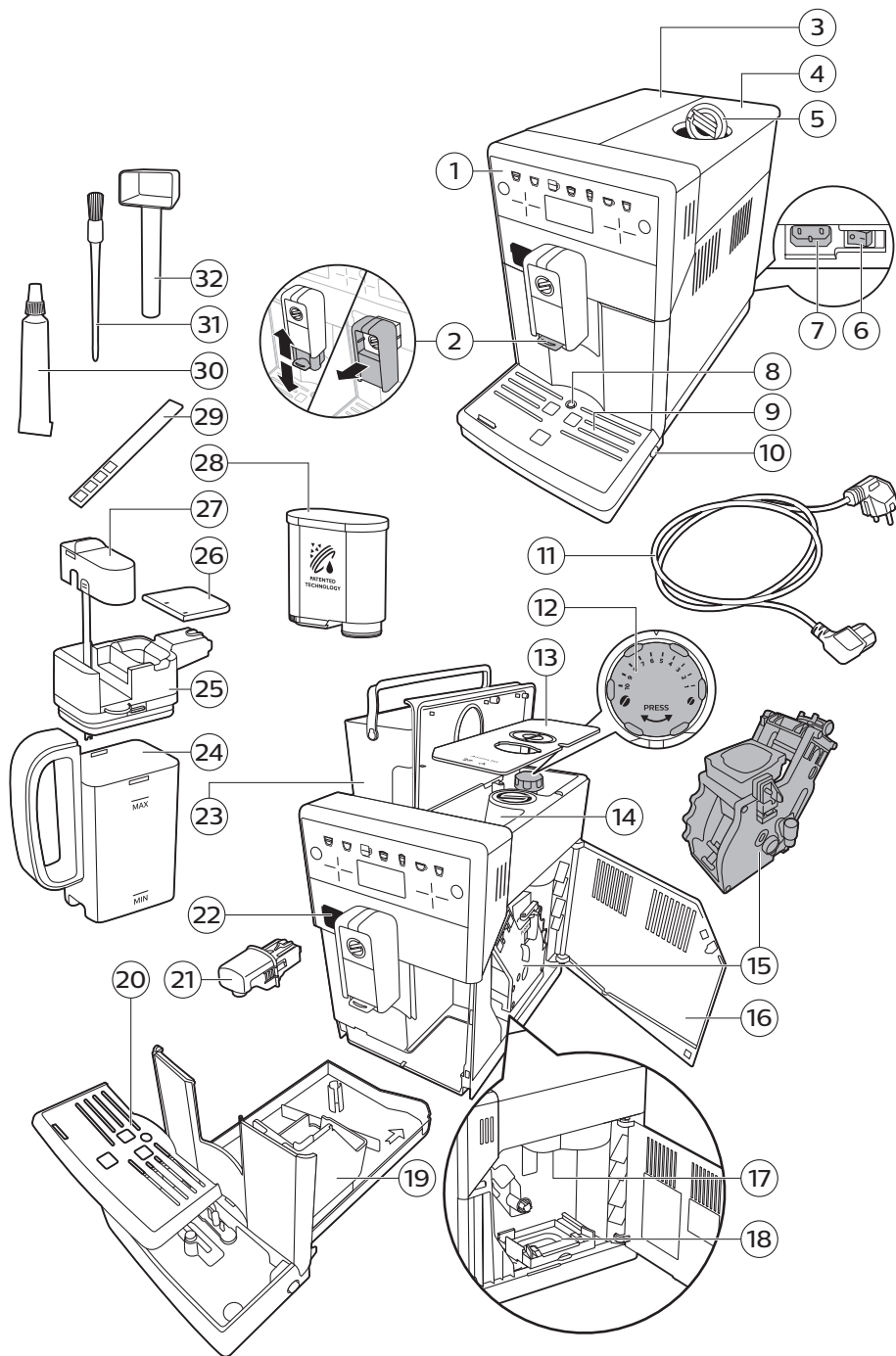

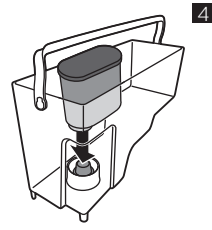
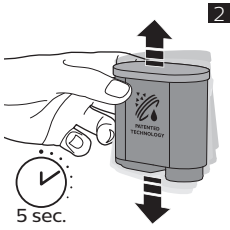

AQUACLEAN
WATER HARDNESS
STAND-BY TIME

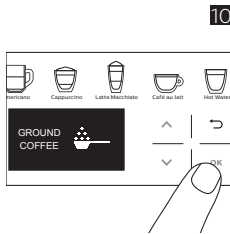
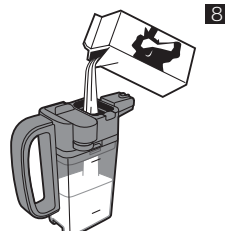

LATTE MACCHIATO
▶ TO START
OK TO SAVE

ESPRESSO
COFFEE
AMERICANO*
CAPPUCCINO*

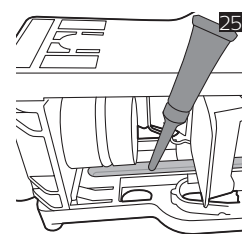
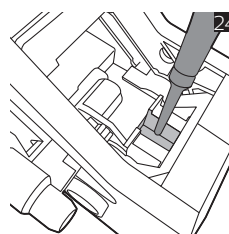
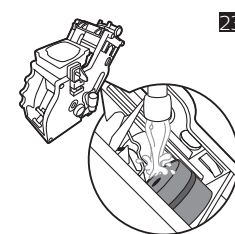
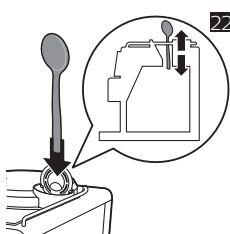
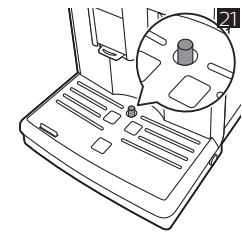
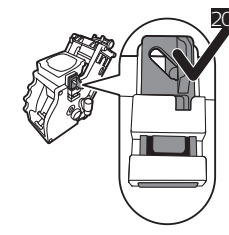
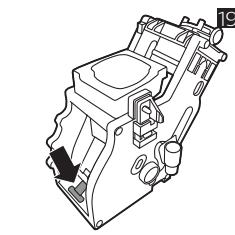
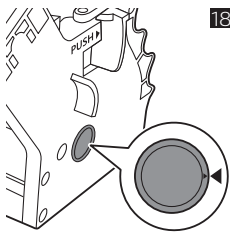
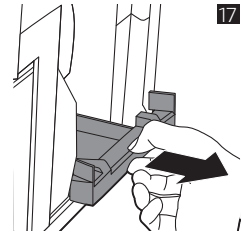
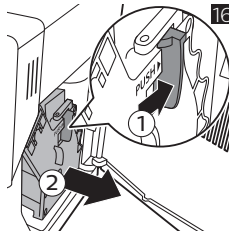
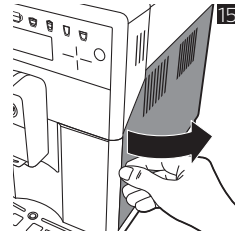
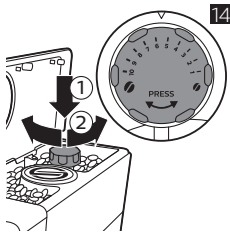

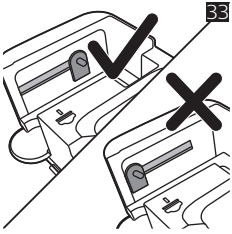
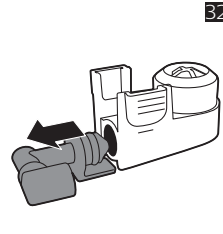
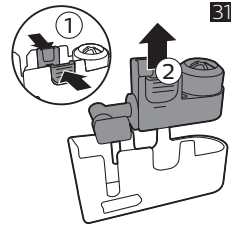
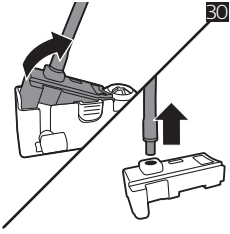
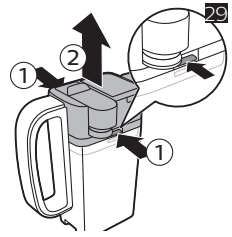
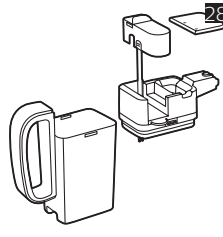
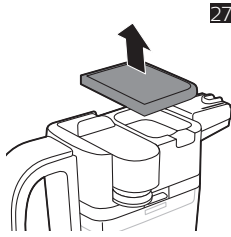
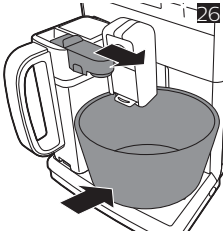

English 6
Dansk 21
Deutsch 37
Español 55
Français 72
Italiano 89
Nederlands 106
Norsk 123
Português 139
Suomi 156
Svenska 172
Ελληνικά 188

Contents

Machine overview (Fig. 1)	6
Introduction	7
First installation	7
AquaClean filter	7
Measuring water hardness	8
Using the control panel	8
Brewing drinks	9
Personalizing drinks and creating profiles	10
Adjusting grinder settings	11
Handling the brew group	11
Cleaning and maintenance	12
Descaling procedure	15
Error codes	16
Ordering accessories	16
Troubleshooting	17
Technical specifications	20

Machine overview (Fig. 1)

1 Control panel	17 Coffee funnel
2 Adjustable/removable coffee dispensing spout	18 Coffee residues drawer
3 Lid of water tank	19 Coffee grounds container
4 Lid of bean hopper	20 Drip tray cover
5 Lid of pre-ground coffee compartment	21 Hot water dispensing spout
6 Main switch	22 Opening for hot water dispensing spout
7 Socket for cord	23 Water tank
8 Drip tray full indicator	24 Milk container
9 Drip tray	25 Top of milk carafe
10 Drip tray release button	26 Lid of milk carafe
11 Mains cord with plug	27 Milk spout and milk tube
12 Grind setting knob	28 AquaClean filter
13 Cover of bean hopper	29 Water hardness test strip
14 Bean hopper	30 Grease tube
15 Brew group	31 Cleaning brush
16 Service door	32 Measuring scoop

Introduction

Congratulations on your purchase of a Saeco full-automatic coffee machine! To fully benefit from the support that Saeco offers, please register your product at www.saeco.com/care.

Read the separate safety booklet carefully before you use the machine for the first time and save it for future reference.

To help you get the best out of your coffee machine, Saeco offers full support in 3 different ways:

- 1 The separate quick start guide for first installation and first use.
- 2 This user manual for more detailed information.
- 3 Online support and movies: scan the QR code on the front page or visit www.saeco.com/care

Note: This machine has been tested with coffee. Although it has been carefully cleaned, there may be some coffee residues left. We guarantee, however, that the machine is absolutely new.

First installation

To prepare your coffee machine for use, you need to perform a few simple steps such as filling the water circuit and activating the AquaClean filter. These steps are shown in the separate quick start guide.

For the best-tasting coffee, you need to brew 5 coffees initially to allow the machine to complete its self-adjustment.

The machine has been set up to get the best taste out of your coffee beans. Therefore we advise you not to adjust the grinder settings until you have brewed 100-150 cups (approx. 1 month of usage).

AquaClean filter

The AquaClean filter is designed to reduce limescale deposits in your coffee machine and provide filtered water to preserve the aroma and flavor of each cup of coffee. If you use a series of 8 AquaClean filters as indicated by the machine and in this user manual, you don't have to descale your machine for up to 5000 cups. With each filter you can enjoy up to 625 cups, depending on the selected coffee varieties and the rinsing and cleaning frequencies.

Preparing the AquaClean filter for activation

Before you place the AquaClean filter in the water tank, you need to prepare it for use:

- 1 Shake the filter for about 5 seconds (Fig. 2).
- 2 Immerse the filter upside down in a jug with cold water and wait until no more air bubbles come out (Fig. 3).
- 3 Push the filter onto the filter connection to the lowest possible point. (Fig. 4)

Activating the AquaClean filter

You need to activate every new AquaClean filter that you use. By activating the AquaClean filter, the machine monitors the capacity of the AquaClean filter and the number of filters used. There are 3 ways to activate the AquaClean filter.

1. Activating the AquaClean filter during first installation

After switching on for the first time, the machine guides you through the first installation steps such as filling the water tank, filling the water circuit and activating the AquaClean filter. Simply follow the instructions on the screen.

8 English

2. Activating the AquaClean filter after replacement

Replace the AquaClean filter when the screen shows the message 'Replace AquaClean filter?' or after 3 months of use. Then follow the instructions on the screen to activate the filter properly.

3. Activating the AquaClean filter at any other time

You can start using the AquaClean filter at any time by following the instructions below.

- 1 Tap the Settings  icon and use the up and down icons to select 'AquaClean' (Fig. 5).
- 2 Tap the OK icon. When the activation screen appears, tap the OK icon again.
- 3 Follow the instructions on the screen.

Note: In some situations the machine will tell you that you need to descale the machine before you can install and activate a new AquaClean filter. This is because your machine has to be completely limescale-free before you start to use the AquaClean filter. Follow the instructions on the screen.

Measuring water hardness

During first installation, you have to set the water hardness. Follow the steps on the screen and use the water hardness test strip supplied. To set the water hardness later, tap the Settings  icon and select 'water hardness'.

- 1 Immerse the water hardness test strip in tap water for 1 second. Then wait for 1 minute.
- 2 Check how many squares have turned red.
- 3 Select the appropriate water hardness setting and tap the OK icon to confirm.

Number of red squares:				
Value to be set	1	2	3	4

Using the control panel

Below you find an overview and description of the control panel of the machine. Use the up and down arrows to scroll through the display and tap the OK icon to select or confirm your choices.

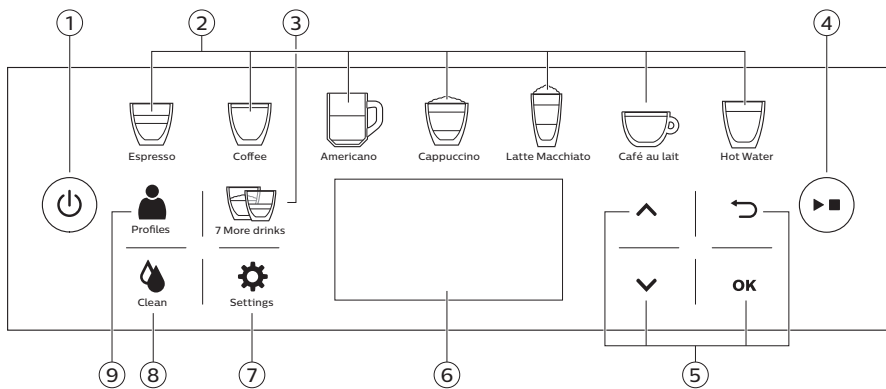

- | | | |
|----------------------------|--|----------------------|
| 1. On/off button | 4. Start/stop  button | 7. Machine settings |
| 2. One-touch drink icons | 5. Navigation icons (up, down, back, ok) | 8. Cleaning menu |
| 3. Menu with 7 more drinks | 6. Display | 9. Personal profiles |

Brewing drinks

You can select a drink by tapping one of the one-touch drink icons (Fig. 6) or by tapping the '7 more drinks' icon and selecting another drink. After selecting a drink, you can personalize it by adjusting the settings. You can also select a personalized drink from a profile by first selecting the profile and then selecting the drink.

- To brew two cups, first tap a one-touch drink icon and then press the start/stop ►■ button twice in quick succession. You can also brew two cups by tapping a one-touch drink icon twice in quick succession and then pressing the start/stop ►■ button. To brew two cups of another drink, go to the '7 more drinks' menu, select a drink and press the start/stop ►■ button twice in quick succession. The machine automatically carries out two grinding cycles in sequence. This is possible for all coffee drinks, except milk-based drinks and hot water.
- To stop dispensing a drink or coffee, press the start/stop ►■ button.
- Slide the dispensing spout up or down to adjust the height to the size of the cup or glass you are using.
- You can remove the adjustable coffee spout, when you use higher glasses.
- When you select AMERICANO, the machine first dispenses coffee and then water.

Brewing coffee

- 1 Fill the water tank with tap water and fill the bean hopper with beans.
- 2 Tap one of the one-touch drink icons (Fig. 6) or tap the '7 more drinks' icon to select another drink.
- 3 Use the up and down arrows (Fig. 7) to adjust the coffee strength. Tap the OK button if you want to adjust more settings.
- 4 Press the start/stop ►■ button at any time to start brewing the selected drink, or after adjusting all settings tap the OK icon if you want to save your settings to a profile (see 'Creating a profile').

Brewing milk-based drinks and milk froth

For more information on how to use the milk carafe, read the separate quick start guide or scan the QR code on the cover of this user manual to access the dedicated website for instruction videos.

Caution: Make sure that the milk carafe is installed and the milk spout is open before you select a milk-based drink or milk froth. If the milk carafe is not installed correctly, steam and hot milk may spray out of the milk spout.

- 1 Fill the water tank with tap water and fill the bean hopper with beans.
- 2 Remove the lid of the milk carafe and fill the milk container with milk. Then place back the lid (Fig. 8).
Always use milk coming directly from the fridge for optimal results.
- 3 Install the milk carafe and open the milk spout.
- 4 Place a cup under the open milk spout.
- 5 Tap one of the one-touch drink icons (Fig. 6) or tap the '7 more drinks' icon to select another drink.
- 6 Use the up and down arrows (Fig. 7) to adjust the coffee strength. Tap the OK button if you want to adjust more settings.
- 7 Press the start/stop ►■ button at any time to start brewing the selected drink, or after adjusting all settings, tap the OK icon if you want to save your settings to a profile (see 'Personalizing drinks and creating profiles').

10 English

- 8 After brewing milk-based drinks, the display asks you if you want to perform the quick clean procedure for the milk carafe. You have 10 seconds to activate the QUICK MILK CLEAN program (see 'Milk carafe cleaning programs'). You can perform the quick clean procedure while leaving the milk inside the milk container. It is recommended to perform the quick clean procedure at least once a day. Press the OK button to confirm that you want to perform the quick clean procedure or press the 'back' icon to perform the quick clean procedure later.

Brewing coffee with pre-ground coffee

- 1 Open the lid and pour one measuring scoop of pre-ground coffee into the pre-ground coffee compartment. Then close the lid (Fig. 9).
- 2 Use the up and down arrows to select pre-ground coffee (Fig. 10). Tap the OK button if you want to adjust the settings. Then press the start/stop ► button.

Note: If you select ground-coffee, you cannot adjust the coffee strength and brew more than one drink at the same time.

Dispensing hot water

- 1 Insert the hot water dispensing spout.
- 2 Press the one-touch 'Hot water' icon (Fig. 11).
- 3 Press the start/stop ► button to start dispensing hot water.

Personalizing drinks and creating profiles

This machine allows you to adjust the settings of a drink to your own preference and to save the adjusted drink in a personal profile. The different profiles have different colours and are either ACTIVE or NEW. An ACTIVE profile already contains customized drinks. A NEW profile does not contain customized drinks yet. The white SAECO profile is the default profile. There are two ways to create a profile:

- 1 When brewing a drink: Press the OK icon to adjust the settings of the selected drink. After adjusting all settings, tap the OK icon to save the personalized drink to a profile. Note that the personalized drink will be saved in the profile you are in, unless you are in the Saeco profile. In that case, you can choose the profile in which you want to save the personalized drink (either in an ACTIVE profile or a NEW profile).
- 2 Via the 'Profiles' menu: Select a profile and then personalize the drinks one by one.

Personalizing your drinks

You can adjust the settings to your own preference:

- 1 Tap one of the one-touch drink icons or tap the '7 more drinks' icon to select your preferred drink (Fig. 6).
- 2 Use the up and down arrows (Fig. 7) to adjust the coffee strength. Tap the OK button if you want to adjust more settings. The screen shows the settings you can adjust to your preference. Depending on the type of drink, you can adjust strength, volume of coffee, milk and water, temperature and taste.
- 3 Use the up and down arrows to set your preferred level (Fig. 7) and tap the OK icon to confirm. Depending on the type of drink, the next adjustable setting appears on the screen.
- 4 After customizing all settings, tap the OK icon to save these settings to your profile (Fig. 12).

Creating a profile

- 1 Tap the Profiles  icon repeatedly to select one of the profiles. All profiles have different colors. You can also use the up and down icons to select your profile.
- 2 Tap the OK icon to customize the profile.
- 3 Use the up and down arrows to select the drink you want to customize and tap the OK icon to confirm.
- 4 Use the up and down arrows to adjust the settings to your preference and tap the OK icon to confirm. Customized drinks are marked with an asterisk (*) (Fig. 13).

Adjusting grinder settings

You can adjust the grinder settings by using the grind setting knob inside the bean container. There are 12 different grind settings you can choose from. The lower the setting, the stronger the coffee.

Note: You can only adjust the grind settings when the machine is grinding coffee beans. You need to brew 2 to 3 drinks before you can taste the full difference.

Caution: Do not turn the grind setting knob more than one notch at a time to prevent damage to the grinder.

- 1 Place a cup under the coffee dispensing spout.
- 2 Open the lid of the bean hopper.
- 3 Tap the ESPRESSO icon. Then press the start/stop  button.
- 4 When the grinder starts grinding, press down the grind setting knob and turn it to the left or right (Fig. 14).

Handling the brew group

Go to www.saeco.com/care for detailed video instructions on how to remove, insert and clean the brew group.

Removing the brew group from the machine

- 1 To switch off the machine, first press the on/off button on the control panel and then set the main switch on the back of the machine to 'O'.
- 2 Remove the drip tray with the coffee grounds container.
- 3 Open the service door (Fig. 15).
- 4 Press the PUSH button (1) and pull at the grip of the brew group to remove it from the machine (2) (Fig. 16).
- 5 Remove the coffee residues drawer (Fig. 17).

Reinserting the brew group

Before you slide the brew group back into the machine, make sure it is in the correct position.

- 1 Check if the arrow on the yellow cylinder on the side of the brew group is aligned with the black arrow and N (Fig. 18).
 - If they are not aligned, push down the lever until it is in contact with the base of the brew group (Fig. 19).
- 2 Make sure that the yellow locking hook on the other side of the brew group is in the correct position.

12 English

- To position the hook correctly, push it upwards until it is in uppermost position (Fig. 20).
- 3 Place back the coffee residues drawer.
- 4 Slide the brew group back into the machine along the guiding rails on the sides until it locks into position with a click. Do not press the PUSH button.
- 5 Close the service door and then place back the drip tray with coffee grounds container.

Cleaning and maintenance

Regular cleaning and maintenance keeps your machine in top condition and ensures good-tasting coffee for a long time, a steady coffee flow and a perfect milk froth.

Consult the table on when and how to clean all detachable parts of the machine. You can find more detailed information and video instructions on www.saeco.com/care.

Cleaning table

Part description	When to clean	How to clean
Brew group	Weekly	Remove the brew group and rinse it under the tap (see 'Cleaning the brew group under the tap').
	Monthly	Perform the 'Brew group clean' program with the Philips coffee oil remover tablet. Select 'Brew group clean' in the cleaning menu and follow the instructions on the screen. Go to www.saeco.com/care for detailed video instructions.
Lubrication of the brew group	Depending on the type of usage. Consult the lubrication table (see 'Lubricating the brew group').	Lubricate the brew group with the Philips grease. Go to www.saeco.com/care for detailed video instructions.
Milk carafe	After every use	Perform the QUICK MILK CLEAN program when prompted by the machine after preparing a milk-based drink and follow the instructions on the screen.
	Daily	Disassemble the milk carafe (see 'Manual cleaning of the milk carafe') and rinse all parts under the tap. Select the QUICK MILK CLEAN program in the menu, if you did not already perform this program after preparing a milk-based drink. Follow the instructions on the screen.
	Weekly	Disassemble the top of the milk carafe (see 'Manual cleaning of the milk carafe') and rinse all parts under the tap.
	Monthly	Perform the DEEP MILK CLEAN program by tapping the Clean  icon and selecting DEEP MILK CLEAN. Use Philips milk circuit cleaner CA6705 for this cleaning program.

Part description	When to clean	How to clean
Drip tray	Empty and clean the drip tray as soon as the red 'drip tray full' indicator pops up through the drip tray (Fig. 21).	Remove the drip tray and rinse it under the tap with some washing-up liquid.
Coffee grounds container	Empty and clean the coffee grounds container when prompted by the machine.	Remove the coffee grounds container while the machine is switched on and rinse it under the tap with some washing-up liquid.
Water tank	Weekly	Rinse the water tank under the tap
Coffee funnel	Check the coffee funnel weekly to see if it is clogged.	Unplug the machine and remove the brew group. Open the lid of the pre-ground coffee compartment and insert the spoon handle into the coffee funnel. Move the handle up and down until the clogged ground coffee falls down (Fig. 22). Go to www.saeco.com/care for detailed video instructions.

Tip: There is a cleaning calendar on the last page of this user manual. Write down the dates on which you have performed a cleaning action.

Cleaning the brew group

Regular cleaning of the brew group prevents coffee residues from clogging up the internal circuits. Visit www.saeco.com/care for support videos on how to remove, insert and clean the brew group.

Cleaning the brew group under the tap

- 1 Remove the brew group (see 'Removing the brew group from the machine').
- 2 Rinse the brew group thoroughly with water. Carefully clean the upper filter (Fig. 23).
- 3 Let the brew group air-dry before you place it back. Do not dry the brew group with a cloth to prevent fibers from collecting inside the brew group.

Cleaning the brew group with the coffee oil remover tablets

Only use Philips coffee oil remover tablets. Tap the Clean  icon and select 'Brew group clean'. Then follow the instructions on the screen. Visit www.saeco.com/care for detailed video instructions.

Lubricating the brew group

Lubricate the brew group regularly to ensure that the moving parts continue to move smoothly.

- 1 Apply a thin layer of grease around the shaft in the bottom of the brew group (Fig. 24).
- 2 Apply a thin layer of grease to the rails on both sides (Fig. 25).

See the table below for the lubrication frequency. Visit www.saeco.com/care for detailed video instructions.

Usage frequency	Nr of drinks brewed daily	Lubrication frequency
Low	1-5	Every 4 months
Normal	6-10	Every 2 months
Heavy	>10	Every month

Cleaning the milk carafe

Milk carafe cleaning programs

The machine has 2 programs to clean the milk carafe: the QUICK MILK CLEAN and the DEEP MILK CLEAN program. You can select these programs by tapping the Clean  icon and scrolling through the cleaning menu. Then follow the instructions on the screen. The machine also prompts you to perform the QUICK MILK CLEAN program after preparing a milk-based drink.

- QUICK MILK CLEAN: the machine cleans the milk spout. You can leave the milk in the container while performing this program.
- DEEP MILK CLEAN: the machine performs a thorough clean of the internal milk system. Use the Philips milk circuit cleaner for this cleaning program.

Manual cleaning of the milk carafe

Below you find an overview and description of the different parts of the milk carafe and the milk spout.

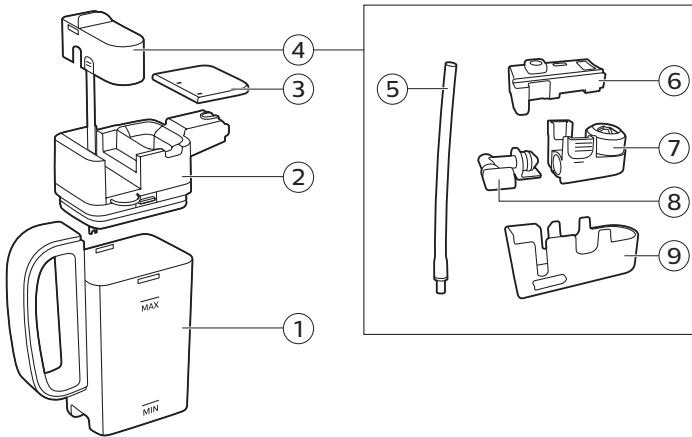

1. Milk container	4. Milk spout	7. Milk frother with connector
2. Top of milk carafe	5. Milk tube	8. Milk frother connector
3. Lid of milk carafe	6. Rubber support	9. Housing of milk spout

Disassembling the top of milk carafe

- 1 Press the release buttons on both sides of the top of the milk carafe (1) and lift it off the milk container (2) (Fig. 29).
- 2 Remove the milk spout from the top of milk carafe. Turn the spout upside down and hold it firmly in your hand. Then pull the milk tube and the rubber support out of the spout and remove the tube from the support (Fig. 30).
- 3 Press the release buttons on the milk frother and remove the milk frother from the support (Fig. 31).
- 4 Pull the milk frother connector out of the milk frother (Fig. 32).
- 5 Rinse all components under a lukewarm tap.

Reassembling the top of milk carafe

- 1 To reassemble the milk spout, follow steps 2 to 4 of 'Disassembling the top of milk carafe' in reverse order.
- 2 Place the milk spout back in the top of milk carafe.
- 3 Place the top of milk carafe back onto the milk carafe.

Note: Before you place the milk spout back into the top of milk carafe, move the pin inside the top to the correct position. If this pin is not in the correct position, you cannot place the milk spout back into the top of the milk carafe (Fig. 33).

Descaling procedure

Please use Philips descaler only. Under no circumstances should you use a descaler based on sulfuric acid, hydrochloric acid, sulfamic or acetic acid (vinegar) as this may damage the water circuit in your machine and not dissolve the limescale properly. Not using the Philips descaler will void your warranty. Failure to descale the appliance will also void your warranty. You can buy Philips descaling solution in the online shop at www.saeco.com/care.

- 1 When the machine asks you to descale it, press the start/stop ►■ button to start. To start descaling without being prompted by the machine, tap the Clean ☕ icon and select 'DESCALING'. Then follow the instructions on the screen to start the descaling procedure.
- 2 Remove the drip tray and the coffee grounds container, empty them and put them back into place.
- 3 Remove the water tank and empty it. Then remove the AquaClean filter.
- 4 Pour the whole bottle of Philips descaler in the water tank and then fill it with water up to the CALC CLEAN level (Fig. 34). Then place it back into the machine.
- 5 Remove and rinse the milk carafe. Fill the milk carafe with water up to the MIN level indication. Insert the milk carafe into the machine and open the milk froth spout.
- 6 Place a large bowl (1.5 l) under the coffee dispensing spout.
- 7 The descaling procedure lasts approx. 20 minutes and consists of a descaling cycle and a rinsing cycle.
- 8 Wait until the machine stops dispensing water.
- 9 Once the descaling cycle is finished, you need to rinse the water tank and water circuit. Follow the instructions on the screen.
- 10 Place a new AquaClean filter in the water tank.

Tip: Using the AquaClean filter reduces the need for descaling!

What to do if the descaling procedure is interrupted

You can exit the descaling procedure by pressing the on/off button on the control panel. If the descaling procedure is interrupted before it is completely finished, do the following:

- 1 Empty and rinse the water tank thoroughly.
- 2 Fill the water tank with fresh water up to the CALC CLEAN level indication and switch the machine back on. The machine will heat up and perform an automatic rinsing cycle.
- 3 Before brewing any drinks, perform a manual rinsing cycle. To perform a manual rinsing cycle, first dispense half a water tank of hot water and then brew 2 cups of pre-ground coffee without adding ground coffee.

Note: If the descaling procedure was not completed, the machine will require another descaling procedure as soon as possible.

Error codes

Below you find a list of the error codes showing problems that you can solve yourself. Video instructions are available on www.saeco.com/care. If another error code appears, please contact the Philips Consumer Care Center in your country. For contact details, see the warranty leaflet.

Error code	Problem	Possible solution
01	The coffee funnel is clogged.	Switch off the machine and unplug it. Remove the brew group. Then open the lid of the pre-ground coffee compartment and insert the spoon handle. Move the handle up and down until the clogged ground coffee falls down (Fig. 22). Visit www.saeco.com/care for detailed video instructions.
03	The brew group is dirty or not well-greased.	Switch off the machine with the main switch. Rinse the brew group with fresh water, let it air-dry and then lubricate it. Consult chapter 'Cleaning the brew group' or visit www.saeco.com/care for detailed video instructions. Then switch the machine on again.
04	The brew group is not positioned correctly.	Switch off the machine with the main switch. Remove the brew group and reinsert it. Make sure that the brew group is in the correct position before you insert it. Consult chapter 'Handling the brew group' or visit www.saeco.com/care for detailed video instructions. Then switch the machine on again.
05	There is air in the water circuit.	Restart the machine by switching it off and on again with the main switch. If this works, dispense 2-3 cups of hot water. Descale the machine if you have not done so for a longer period of time.
	The AquaClean filter was not prepared properly before installation or it is clogged.	Remove the AquaClean filter and try again to brew a coffee. If this works, make sure that the AquaClean filter is prepared properly before you place it back (see 'Preparing the AquaClean filter for activation'). Put the AquaClean filter back into the water tank. If this still does not work, the filter is clogged and needs to be replaced.
14	The machine is overheated.	Switch the machine off and switch it back on again after 30 minutes.

Ordering accessories

To clean and descale the machine, only use the Philips maintenance products. These products can be purchased from your local retailer, from the authorized service centers or online at www.saeco.com/care.

Maintenance products and type numbers:

- Descaling solution CA6700
- AquaClean filter CA6903
- Brew group grease HD5061
- Coffee oil remover tablets CA6704
- Milk circuit cleaner CA6705
- Maintenance kit CA6707

Troubleshooting

This chapter summarizes the most common problems you could encounter with the machine. Support videos and a complete list of frequently asked questions are available on www.saeco.com/care. If you are unable to solve the problem, contact the Consumer Care Center in your country. For contact details, see the warranty leaflet.

Problem	Cause	Solution
The drip tray fills up quickly.	This is normal. The machine uses water to rinse the internal circuit and brew group. Some water flows through the internal system directly into the drip tray.	Empty the drip tray when the 'drip tray full' indicator pops up through the drip tray cover (Fig. 21). Place a cup under the dispensing spout to collect rinsing water.
The machine is in DEMO mode.	You pressed the standby button for more than 8 seconds.	Switch the machine off and then on again with the main switch on the back of the machine.
The message 'Empty the coffee grounds container' still remains displayed.	The machine does not detect that the coffee grounds container has been emptied if the machine is switched off.	Always empty the coffee grounds container while the machine is switched on. If you empty the coffee grounds container when the machine is switched off, the coffee grounds counter will not be reset.
	The machine does not detect that the coffee grounds container has been emptied if you place back the coffee grounds container too fast.	Do not place back the coffee grounds container until the screen prompts you to put it back.
The machine prompts me to empty the coffee grounds container even though the container is not full.	The machine did not reset the counter the last time you emptied the coffee grounds container.	Always wait approx. 5 seconds when you place back the coffee grounds container. In this way, the coffee grounds counter will be reset to zero.
		Always empty the coffee grounds container while the machine is switched on. If you empty the coffee grounds container when the machine is switched off, the coffee grounds counter will not be reset.
The coffee grounds container is overfilled and the message 'Empty grounds container' did not display.	You removed the drip tray without emptying the grounds container.	When you remove the drip tray, also empty the coffee grounds container even if it contains only a few coffee grounds. In this way, the coffee grounds counter will be reset to zero and will continue to count correctly.

18 English

Problem	Cause	Solution
I cannot remove the brew group.	The brew group is not in the correct position.	Reset the machine in the following way: place back the drip tray and the coffee grounds container. Then close the service door and switch the machine off and back on again. Try again to remove the brew group.
	You have not removed the coffee grounds container.	Remove the coffee grounds container before you remove the brew group.
	The machine is still in the descaling procedure.	You cannot remove the brew group when the descaling procedure is in progress. First complete the descaling procedure and then remove the brew group.
I cannot insert the brew group.	The brew group is not in the correct position.	Reset the machine in the following way: place back the drip tray and the coffee grounds container. Leave the brew group out. Close the service door and switch the machine on and off. Then put the brew group in the correct position and reinsert it into in the machine.
The coffee is watery.	The grinder is set to a too coarse setting.	Set the grinder to a finer (lower) setting.
	The coffee exit duct is clogged.	Clean the coffee exit duct with the spoon handle. Then switch the machine off and on again.
	The machine is performing its self-adjustment procedure.	Brew a few cups of coffee.
	The brew group is dirty or needs to be lubricated.	Clean and lubricate the brew group.
The coffee is not hot enough.	The cups you use are cold.	Preheat the cups by rinsing them with hot water.
	The temperature is set too low. Check the product settings.	Set the temperature to 'high' in the product settings.
	You added milk.	Whether the milk you add is warm or cold, it always decreases the temperature of the coffee to some extent.
Coffee does not come out or coffee comes out slowly.	The AquaClean filter was not prepared properly for installation or it is clogged.	Remove the AquaClean filter and try to brew a coffee again. If this works, make sure the AquaClean filter is prepared properly before you place it back. Place back the prepared filter. If this still does not work, the filter is clogged and needs to be replaced.

Problem	Cause	Solution
	The grinder is set to a too fine setting.	Set the grinder to a coarser (higher) setting.
	The brew group is dirty.	Clean the brew group.
	The coffee dispensing spout is dirty.	Clean the coffee dispensing spout and its holes with a needle.
	The machine circuit is blocked by limescale.	Descale the machine.
I press the start/stop button twice, but the machine does not brew two cups of coffee.	You waited too long before pressing the start/stop button for the second time.	Press the start/stop button in quick succession. If you wait too long before pressing the button again, the stop-function is activated.
The milk does not froth.	The milk carafe is dirty or not inserted correctly.	Clean the carafe and make sure that you position and insert it correctly.
	The milk spout has not been opened fully.	Make sure that the milk spout is in the correct position.
	The milk carafe is incompletely assembled.	Make sure that all the components (especially the milk tube) have been assembled correctly
	The type of milk used is not suitable for frothing.	Different types of milk result in different amounts of froth and different froth qualities. We have tested the following milk types which proved to deliver a good milk froth result: semi-skimmed or full-fat cow's milk, soy milk and lactose-free milk. Other types of milk have not been tested and may result in a small amount of milk froth.
The milk is splashing.	The milk you use is not cold enough.	Make sure you use cold milk coming directly from the fridge.
The machine seems to be leaking.	The machine uses water to rinse the internal circuit and brew group. Some water flows through the internal system directly into the drip tray.	Empty the drip tray when the 'drip tray full' indicator pops up through the drip tray cover (Fig. 21). Place a cup under the dispensing spout to collect rinsing water.
	The drip tray is too full and has overflowed which makes it look like the machine is leaking.	Empty the drip tray when the 'drip tray full' indicator pops up through the drip tray cover (Fig. 21). Place a cup under the dispensing spout to collect rinsing water.
	The machine is not placed on a horizontal surface.	Place the machine on a horizontal surface so that the 'drip tray full' indicator works properly.

Problem	Cause	Solution
I cannot activate the AquaClean filter and the machine asks for descaling.	The filter has not been replaced in time after the AquaClean filter icon flashed and the capacity dropped to 0%.	Descalcify your machine first and then install the AquaClean filter.
	You did not install the AquaClean filter during first installation, but after having brewed approx. 25 coffees (based on 100ml cups). The machine has to be completely limescale-free before you install the AquaClean filter.	First descale the machine and then install a new AquaClean filter. After descaling, the filter counter is reset to 0/8. Always confirm filter activation in the machine menu. Also do this after filter replacement.
The new water filter does not fit.	You are trying to install another filter than the AquaClean filter.	Only the AquaClean filter fits into the machine.
The machine is making a noise.	It is normal that your machine makes noise during use.	If the machine starts to make a different kind of noise, clean the brew group and lubricate it (see 'Lubricating the brew group').
The machine does not respond when I tap one of the icons or buttons on the control panel.	You are touching the control panel with wet hands.	Make sure that your hands are dry when you touch the icons or buttons on the control panel.

Technical specifications

The manufacturer reserves the right to improve the technical specifications of the product. All the preset quantities are approximate.

Description	Value
Size (w x h x d)	222 x 335 x 436 mm
Weight	10 - 11 kg
Power cord length	1200 mm
Water tank	1.8 litres, removable
Coffee bean hopper capacity	250 g
Coffee grounds container capacity	15 pucks
Milk carafe capacity	550 ml
Adjustable spout height	81-106 mm
Nominal voltage - Power rating - Power supply	See data plate on inside of service door



4219.440.7804.1 (10/2017) rev.00

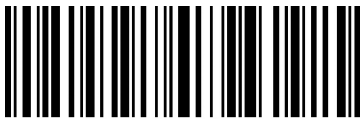

421944078041

www.saeco.com/care



>75% recycled paper
>75% papier recyclé